

PANDJIRIS, INC

5151 Northrup • St. Louis, MO 63110 • (314) 776-6893

4,500 LB. CAPACITY WELDING POSITIONER (MODEL 45-12)

The **Model 45-12 MVRMTFB Positioner** has a motorized variable speed rotation with Forward-Stop-Reverse switch and dynamic braking. The rotation speed is variable from 0.03 to .97 RPM with motorized tilt infinitely variable through 135 degrees. A 48" square table with fixed height at 38-3/4" to allow full tilting capability is standard. All wiring conforms to National Electrical Code Standards. The positioner operates on 230/460 volt, three phase, 60 cycle input power, draws 20.2 Amps at 230V. When ordering specify 230 or 460 volts. A field changeable plug-in hand pendant includes "Forward-Stop-Reverse-Weld/Rapid" buttons and a speed adjustment potentiometer on 25' of cable as standard.

- Load capacity 4,500 lb. 12 inch overhung from face of table, 12 inch eccentricity.
- Rotational motor size 1-1/2 H.P. motor.
- Rotation speed Variable from .03 to .97 RPM.
- Rotation torque 54,000 inch pounds.
- Swing radius 34-15/32" @ 90° tilt.
- Tilt range 0 through 135 degrees, motorized.
- Tilt motor size 1-1/2 H.P. AC Brakemotor.
- Tilt Speed 135 degrees in 30 seconds.
- Tilt Torque 79,875 inch pounds inherent.

The **Model 45-12 MVRMTAB Positioner** is the same as above except with an adjustable base and a swing radius from 34-5/8" to 51-1/8" @ 90° tilt.

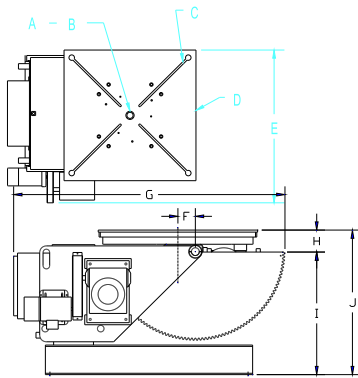

A	Pilot Hole	3" φ x 1/4" Deep
B	Thru Hole	2-1/4" φ
C	"T" Slot Quantity	4
	ANSI Std "T" Nut size	5/8"
D	Table Size	48" sq.
E	Overall Width	54-3/16"
F	Rotation Offset	5"
G	Overall Length	67-11/16"
H	Inherent Overhang	5-3/4"
I	Tilt Axis Height	33-1/4"
J	Table Height	min 39"
	(4) Positions	max 57"

Terms: Pandjiris, Inc. standard terms and conditions apply, f.o.b. Factory, St. Louis, Missouri, or designated ship point.

Delivery: Consult Factory

Approximate shipping weight: 3,000 lbs.

PRICE LIST	
For Bulletin No.	: PC 0991
Effective Date	: May, 2005
Page Number	: A-17

PANDJIRIS, INC

5151 Northrup • St. Louis, MO 63110 • (314) 776-6893

POSITIONERS Optional Accessories

Foot switch with compatible plug for Forward/Stop/Reverse (speed potentiometer on hand pendant)

Foot switch, Fast-Slow with compatible plug

Preset digital tachometer with compatible plug reads speed in RPM

Dialweld®, (shows linear speed in IPM for diameter set on diameter selector. Dial diameter to be welded, dial weld speed, table RPM is automatically set to weld diameter at selected welding speed) digital meter with compatible plug reads IPM or CmPM

Tach feedback for precision speed control for Models up to 120-12

25' Extension Cable with compatible plugs for standard pendants and accessories

Model 600 PT Copper Welding Ground

Model 1200 PT Copper Welding Ground

For powered elevation of table height consult factory.

Terms: Pandjiris, Inc. standard terms and conditions apply, f.o.b. Factory, St. Louis, Missouri, or designated ship point.

Delivery: Consult Factory

PRICE LIST

For Bulletin No. : PC 0991
Effective Date : May, 2005
Page Number : A-18